

## VISIBEAM® II SPOTLIGHT



*The VisiBeam® II is a high power spotlight with a handheld control unit.*

For effective work area illumination, Federal Signal's VisiBeam® II high power spotlight features a handheld remote control head with pinpoint accuracy.

The spotlight uses the combination of a highly polished parabolic reflector and halogen bulb to produce a clear, even lightbeam that exceeds both "spot" and "flood" sealed beams. When operating, this powerful light is also energy efficient. The 55-watt version draws only 4.2 amps.

The VisiBeam II spotlight assembly is adjustable upward 105° and downward 35° from horizontal, and it can rotate a complete 360°. For pinpoint placement of the lightbeam, the assembly moves gradually at first and then increases speed to the target. This "graduated start" enables the user to move the light in small increments.

The VisiBeam II's compact remote control head can be operated from the palm of your hand or mounted on the vehicle's dash. This is a great alternative to bulky manual spotlight controls in the cab of the vehicle. Also, an indicator light on the control reminds the user that the spotlight is on.

Installation is quick and easy. The compact control head fits virtually anywhere and can be mounted with Velcro® or a more secure "snap holder" (both are included). The VisiBeam II control head is connected to the light via a 15' "telephone" type cable. Each VisiBeam II is available with a choice of three mounting options: permanent, magnetic, or pipe mount.

### QUICK REFERENCE

#### FEATURES

- Brilliant work area lighting.
- Handheld control unit.
- "Graduated start" for pinpoint accuracy.
- Energy efficient.
- 360° rotation capability.
- Horizontally and vertically adjustable.
- Twist-off dome for easy maintenance.

#### APPLICATIONS

- Scene lighting
- Work area lighting

#### REPLACEMENT PARTS

Bulb, 55-watt	Z8107152A
Bulb, 65-watt	Z8107190A
Bulb, 100-watt	Z8107158A
Dome	Z8433001A
Control cable	Z146903A

#### RELATED PRODUCTS

- GHSCENE Area Light  
Bulletin #4107
- Night-Fighter® Spot/Flood Light  
Bulletin #4112
- Littlite® Gooseneck Lamps  
Bulletin #4130

# MOUNTING DIAGRAM

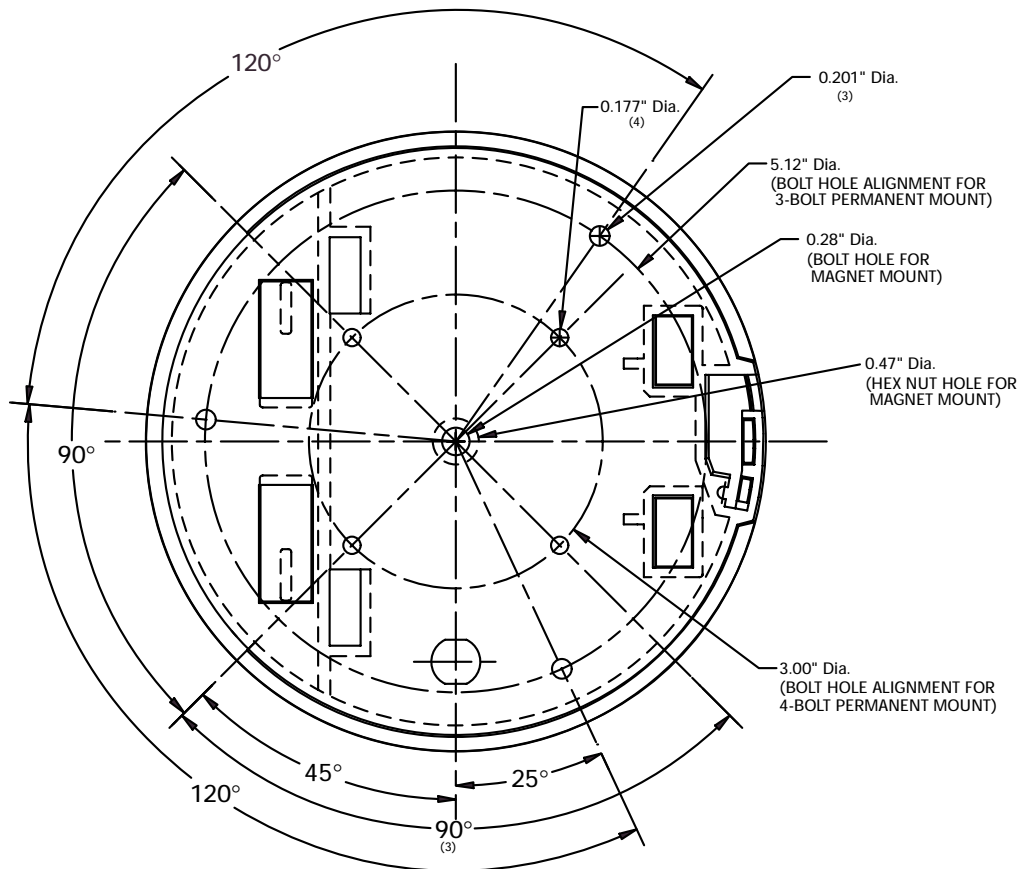

## HOW TO ORDER

### 1. Specify a model.

- 620102** VB12S, 55-watt halogen spotlight assembly with permanent mount kit
- 620122** VB12S1, 100-watt halogen spotlight assembly with permanent mount kit
- VB24S** 65-watt, 24V halogen spotlight assembly with permanent mount kit
- 620132** VB12M, 55-watt halogen spotlight assembly with magnetic mount and cigarette lighter plug with 10' cord
- 620142** VB12M1, 100-watt halogen spotlight assembly with magnetic mount and cigarette lighter plug with 10' cord
- 620152** VB12P1, 100-watt halogen spotlight assembly with pipe mount kit

### FACTORY SET SPECIFICATIONS

Type	Volts	Current Draw
55W, VisiBeam II	12V	4.2 amps @ 12.8 volts
65W, VisiBeam II	24V	2.7 amps @ 24.0 volts
100W, VisiBeam II	12V	7.8 amps @ 12.8 volts

### DIMENSIONS

Model	Height		Diameter		Ship. Weight	
	in.	cm.	in.	cm.	lbs.	kg.
620102	6.5	16.5	6.5	16.5	2.0	0.9
620122	6.5	16.5	6.5	16.5	2.0	0.9
VB24S	6.5	16.5	6.5	16.5	2.0	0.9
620132	6.9	17.5	6.5	16.5	2.0	0.9
620142	6.9	17.5	6.5	16.5	2.0	0.9
620152	7.3	18.4	6.5	16.5	2.0	0.9